

VTX Amplifiers

VTX750, VTX1200, VTX1500

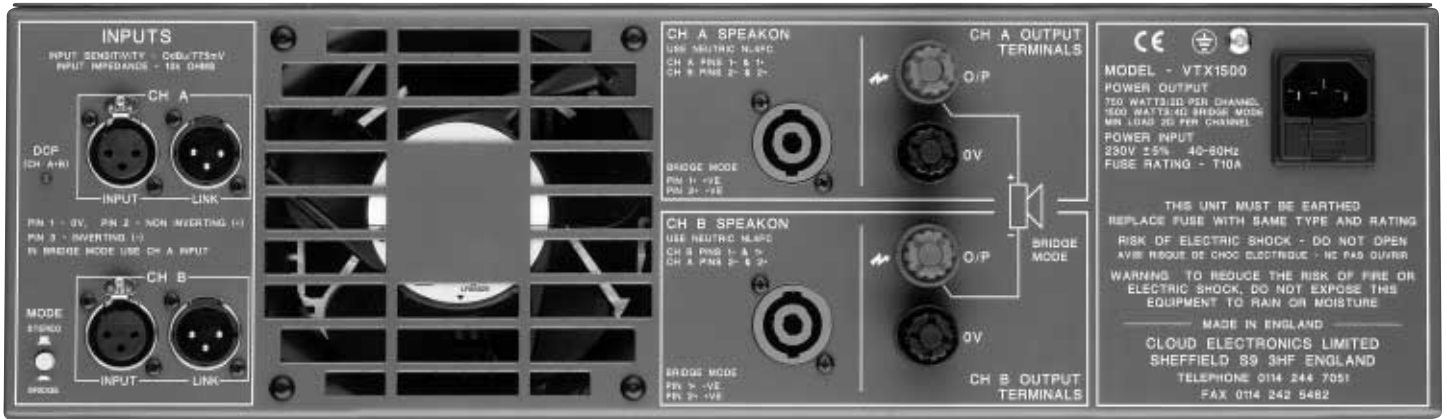

In designing the new VTX Series of power amplifiers, Cloud have set out to satisfy three principal criteria, hitherto regarded as conflicting, but all of great importance in today's venue applications.

Firstly, they have been built to give long, reliable service when operated at sustained high power levels, day after day, time after time. Simply achieving this degree of ruggedness with consistent audio performance would satisfy most designers, but we pressed on.

The second set of design criteria are, we feel, equally important, namely to ensure that the amplifier can protect itself and the speakers connected to it against both casual and persistent abuse. This is why every Cloud VTX amp provides comprehensive protection features, including our own DCP (Dynamic Clip Protection), to minimise the risk of damage and system failure.

The third area where the VTX Series has been equipped to excel is in sheer audio quality. The high quality source material available in today's marketplace demands accuracy and finesse from the amplifier if detail and impact are not to be lost. All the new VTX models have been designed with very low distortion, low noise circuits and given fast rise times and high slew rates for clearly better sound. Any one of these strengths would make a good case for choosing a Cloud VTX Amplifier. Having all three in one advanced, practical and affordable package present a choice which is clearly better.

APPLICATIONS

Applications for the Cloud VTX range of two channel power amplifiers are many and varied; from prestigious discotheques and nightclubs to sports halls and shopping malls, in fact any application where reliability, protection and sonic performance are pre-requisites. The units are engineered to deliver full power for long periods into load impedances as low as 2 ohms.

The standard DCP (Dynamic Clip Protection) ensures maximum output into any load above 2 ohms without clipping the waveform, resulting in fatigue free sound and no clipping related drive unit failures. All models can be switched to operate in the bridge mode where twice the rated output can be delivered into a single 4 ohm load. In the bridge mode, the VTX1500 can be used to provide a high power, balanced 100V line output.

INPUTS

A 3 pin female XLR type connector, wired to the standard convention provides the termination for the electronically balanced input. A 3 pin male XLR type connector is also provided for linking purpose; this connector is wired in parallel with the input socket and can be used to connect several power amplifiers using the "daisy chain" method.

OUTPUT CONNECTIONS

Two types of output connector are provided on the VTX amplifiers: heavy duty binding posts, allowing easy termination of heavy duty cable and two 4 pole "speakon" connectors are provided, each with terminations for both channel A and channel B outputs.

MODE OF OPERATION

A switch is provided on the rear panel which determines the mode of operation. In the "stereo" mode, each channel operates independently with a minimum load of 2 ohms. In the "Bridge" mode, the amplifier operates as a single, high power channel with a minimum load of 4 ohms. The VTX1500 can be used in the bridge mode to provide the power for a

1000 watt 100V line system, with a minimum load of 10 ohms.

COOLING SYSTEM

The reliability of the Cloud VTX power amplifiers is due in no small way to the efficient cooling of the output devices and the power supply components. A high quality 120mm fan with ball bearings is used to provide a long trouble free life. Cool air is drawn in through the front panel, directed across the PSU and the custom heatsink extrusions before exhausting through the rear panel. The use of a 3U rack housing allows the use of heatsinks, power transformers and cooling fans of generous proportions resulting in lower operating temperatures and reducing thermal cycling related failure.

DYNAMIC CLIP PROTECTION

The specially designed DCP circuitry minimises the risk of damage and system failure whilst maintaining optimum sonic integrity, irrespective of load impedance.

Standard fixed level limiters often fitted to power amplifiers suffer from the problem that they assume the amplifier is driving the lowest rated load at a continuous level. Consequently, the limiter will not allow the amplifier to deliver its maximum power into higher impedance loads, nor deliver its maximum transient power. Cloud's DCP circuitry gets round this by detecting when the amplifier distortion increases and reduces the amplifier gain as needed to keep the distortion at a low level, thus preventing noticeable clipping. In addition to clip limiting, DCP also reduces the gain when the amplifier goes into VI limiting, further reducing stress on the output components when the amplifier is driven into a short circuit or low impedance load. VCA chips have not been used in this design, hence avoiding the noise, distortion and slew rate limit which can be associated with them. In fact when the DCP is not limiting, its gain control circuit has no effect on the slew rate and makes no measurable contribution to the amplifier noise or distortion.

The release time is internally adjustable, i.e. fast or slow, to suit the amplifier's application within the system.

SWITCH ON PROTECTION

To prevent high switch on currents which can blow mains fuses or trip MCBs, all models are fitted with inrush current limited power supplies. This provides similar protection to a 'soft start' but without the unreliability which can often come with them. A five second delay is also incorporated to avoid potentially destructive switch on transients.

PROTECTION

VI Limiting

A sophisticated VI limiting circuit protects the amplifiers from short circuit or mismatched loads. The circuits remain fully transparent to musical transients and sonic performance is not compromised.

DC Protection.

A relay with magnetic arc interruption disconnects the speakers in the unlikely event of DC being detected at the output.

Thermal Protection

A thermal switch detects over temperature conditions and disconnects the speakers. This automatically resets once the operating temperature is normalised.

LED STATUS INDICATORS

LEDs on the front panel indicate Protect, Signal Presence, Peak, Bridge Mode and Power On.

Technical Specifications

General Specifications	VTX750	VTX1200	VTX1500
Input	Electronically balanced XLR	Electronically balanced XLR	Electronically balanced XLR
Output Connectors	1 Speakon & 2 heavy duty binding posts per channel	1 Speakon & 2 heavy duty binding posts per channel	1 Speakon & 2 heavy duty binding posts per channel
Protection	VI limiting, DC offset, Thermal shutdown, Inrush current limited	VI limiting, DC offset, Thermal shutdown, Inrush current limited	VI limiting, DC offset, Thermal shutdown, Inrush current limited
LED Indicators	'Peak Output', 'Signal present', 'Protection Operating', 'DCP on'	'Peak Output', 'Signal present', 'Protection Operating', 'DCP on'	'Peak Output', 'Signal present', 'Protection Operating', 'DCP on'
Cooling System	Fan assisted by 120mm low noise fan	Fan assisted by 120mm fan	Fan assisted by 120mm high speed fan
Dimensions	483mm x 370mm x 132mm	483mm x 370mm x 132mm	483mm x 370mm x 132mm
Weight	13.4kg	16.65kg	18.6kg

Technical Specifications	VTX750	VTX1200	VTX1500
Output power at 1kHz <0.2% THD both channels driven			
Rated Output Power 2Ω	375 Watts RMS per channel	600 Watts RMS per channel	780 Watts RMS per channel
Rated Output Power 4Ω	265 Watts RMS per channel	425 Watts RMS per channel	525 Watts RMS per channel
Rated Output Power 8Ω	190 Watts RMS per channel	270 Watts RMS per channel	320 Watts RMS per channel
Bridged Output Power 4Ω	750 Watts RMS	1200 Watts RMS	1560 Watts RMS
Bridged Output Power 8Ω	530 Watts RMS	850 Watts RMS	1050 Watts RMS
Frequency Response	+0 -1dB 10Hz to 50kHz	+0 -1dB 10Hz to 50kHz	+0 -1dB 10Hz to 50kHz
Harmonic Distortion	0.22% typical 1kHz 8Ω load	0.22% typical 1kHz 8Ω load	0.22% typical 1kHz 8Ω load
Input Sensitivity	0dBu - 775mV RMS	0dBu - 775mV RMS	0dBu - 775mV RMS
Input Impedance	10kΩ balanced, 5kΩ unbalanced	10kΩ balanced, 5kΩ unbalanced	10kΩ balanced, 5kΩ unbalanced
Signal to Noise Ratio	100dB below rated output	100dB below rated output	100dB below rated output
Output Rise Time	3μs (10% to 90%) of 1V 1kHz	3μs (10% to 90%) of 1V 1kHz	3μs (10% to 90%) of 1V 1kHz
Slew Rate	45V/μs	45V/μs	45V/μs
DCP Threshold	Variable, automatic	Variable, automatic	Variable, automatic
DCP Attack Time	5ms	5ms	5ms
DCP Maximum Attenuation	20dB	20dB	20dB
DCP Compression Ratio	Infinite	Infinite	Infinite

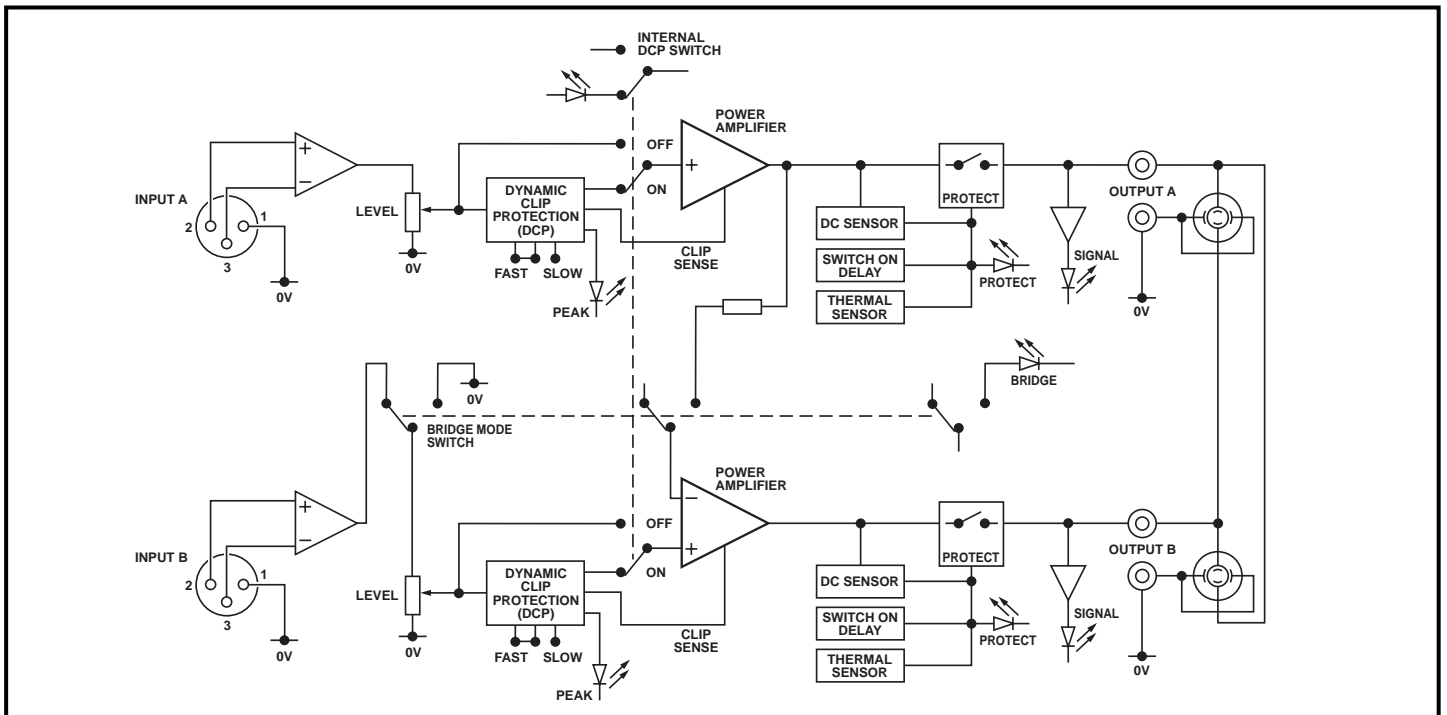

Cloud Electronics Ltd., 140 Staniforth Road, Sheffield, S9 3HF, England. Telephone: (0114) 244 7051 Fax: (0114) 242 5462

E-mail: sales@cloud.co.uk Web site: www.cloud.co.uk