

## Connecting an LM-1 to a Z4/Z8MK3 or 46-120

### Preamble:

The LM-1 remote input/control module is an accessory for the Z4II and Z8II Zone Mixers; it is also compatible with the 46/50 Multi-Zone Mixer Amplifier. When installed in one of the host unit's Zones, it provides a local mic input, line input, and also remote control of background music source and level (as per the Cloud RSL-6 remote control module).

During 2013, the Z4II, Z8II and 46/50 were replaced by newer models: the Z4MK3, Z8MK3 and 46-120 respectively. A redesigned remote input/control module, the LM-2 range, was also introduced. Both the LM-1 and LM-2 connect to the host unit via a single, multicore cable to a Facility Port on the rear panel. On the earlier models, the Facility Port was a 9-pin Dsub connector; on the newer models it is an 8-pin RJ45 type.

This Technical Note describes how to connect an LM-1 module to one of the newer host units. This may be necessary if the host unit in an existing installation is upgraded to one of the newer models, and it is not wished to replace existing remote modules.

The LM-1 Installation Guide describes only the connections and configuration applicable to the older models. While some of the information in the Installation Guide is still valid, this Technical Note should be followed in preference to the Guide to make the correct connections and perform the necessary host configuration.

### Applicable products:

LM-1\* Remote Active Module, used in conjunction with a Cloud product fitted with one or more RJ45 8-pin Facility Ports. Current compatible products are as follows:

- Z4MK3 4 Zone Mixer
- Z8MK3 8 Zone Mixer
- 46-120 4 Zone Integrated Mixer Amplifier
- 46-120MEDIA 4 Zone Integrated Mixer Amplifier with MP3 player

### Limitations:

The 46-120 and 46-120MEDIA have a single Facility Port, on Zone I. Thus an LM-1 used with these products should be located in Zone I.

### Parts required:

- One metal shielded RJ45 plug (all cases), and either:
  - if the LM-1 is being fitted as new installation, screened Cat 5 cable of the necessary length will also be required, or
  - if the LM-1 is already installed and the host unit is being changed, the existing 9-core screened cable should be suitable.
- 9 x crimp ferrules (white)

*(Note that as the cable carries analogue audio, only screened cable and metal shielded connectors should be used).*

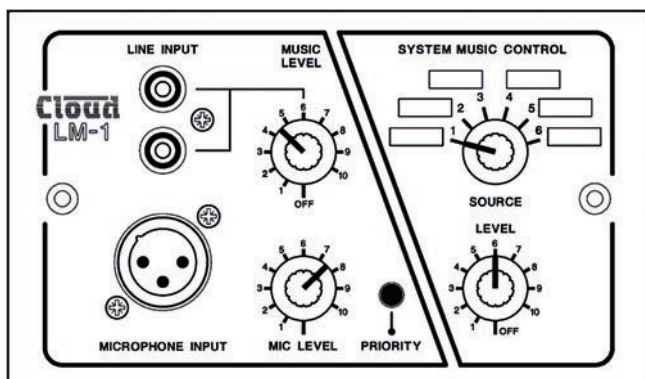

LM-1 front panel

\*The LM-1A is a mechanically different variant which fits USA-size electrical boxes. All details of this Technical Note are also applicable to this version.

**Tools required:** Medium size wire cutters, small flat-blade screwdriver, RJ45 crimp tool, ferrule crimp tool.

**Required Skill Level:** Low.

As no soldering is required, connecting an LM-I to one of the newer host units is easier than connecting it to one of the earlier models.

**Procedure - wiring:**

Connecting an LM-I to an RJ45 Facility Port is only a question of ensuring that each pin of the RJ45 is wired to the correct terminal of the LM-I's connector block, and enabling background music remote control on the host unit.

**New installations:**

If the LM-I is being installed for the first time, run a length of screened Cat 5 cable between its location and the host unit. Crimp a metal shielded RJ45 plug onto the host unit end as follows:

PIN	CAT5 CORE
1	White + Orange
2	Orange
3	White + Green
4	Blue
5	White + Blue
6	Green
7	White + Brown
8	Brown

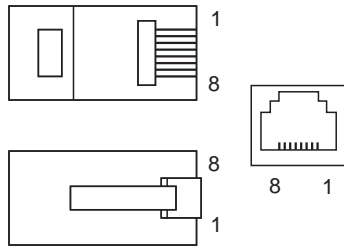

The connector block on the LM-I is CON 1 on the upper PCB.

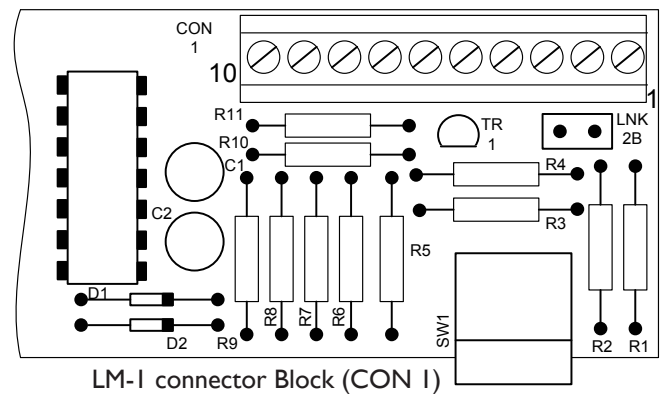

Connect as detailed below:

LM-I TERMINAL	Cat 5 CORE	USE
1	Brown	System Music Source
2	White + Brown	System Music Level
3	Connector shell	Logic ground
4	(n/c)	
5	White + Green	VCA CV (priority)
6	White + Orange	Audio 'cold' (-)
7	Orange	Audio 'hot' (+)
8	White + Blue	0V
9	Green	-15V
10	Blue	+15V

The use of crimp ferrules at the LM-I end is strongly recommended as Cat 5 cable has solid cores, which may not provide a permanently reliable connection in a screw terminal block.

Note that terminal 4 of the LM-I should be left unconnected. This terminal carries the LM-I's noise gate control voltage, which was required by the earlier models of host to trigger the gate circuitry within the host. In the newer models, the gate circuitry is implemented wholly within the host itself, thus this control voltage is not needed.

**Existing installations:**

If the host unit is being replaced by a new unit and the LM-I is already installed, you will need to remove the LM-I from its back box to inspect the existing wiring. Make a note of which colour core of the multi-core cable goes to each terminal of the connector block.

If the existing cable has cores of small enough diameter to seat correctly inside, a metal shielded RJ45 plug may be crimped directly onto the cable according to the table below. If the cores are too big, extend the existing cable with a short length of screened Cat 5 cable using terminal blocks and a small plastic housing or similar, taking care to ensure the pin-to-pin matching shown in the table is retained.

Terminal 4 of the LM-I should be left unconnected – see note on previous page.

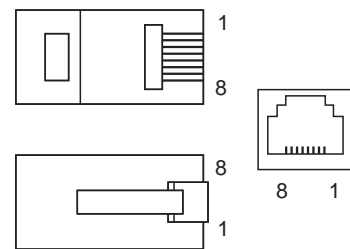

LM-I TERMINAL	USE	RJ45 PIN
1	System Music Source	8
2	System Music Level	7
3	Connector shell	Connector shell
4		(n/c)
5	VCA CV (priority)	3
6	Audio 'cold' (-)	1
7	Audio 'hot' (+)	2
8	0V	5
9	-15V	6
10	+15V	4

### **Procedure - host configuration:**

In order for the remote control section (background music source and level controls to operate correctly), the host unit must be set for remote control operation.

#### **Z4MK3 and Z8MK3:**

Set the MUSIC CONTROL button on the host unit's rear panel to REMOTE (in) for the Zone in use. The button is adjacent to the REMOTE SOURCE + LEVEL connector immediately above the FACILITY PORT. This will disable the host unit's front panel music source and level controls for the Zone.

Sometimes it is desirable to permit remote control of music level but keep music source selectable only on the host unit. In this case, internal jumper J1 on the sub-board for the Zone in use should be moved from 'SW' to 'FR'. This will render the LM-1's music source switch inoperative, and return source selection to the front panel. See the Z4MK3/Z8MK3 Installation and User Guide for full details and jumper locations.

#### **46-120 and 46-120MEDIA:**

These units only have a single Facility Port, for Zone 1. Thus the LM-1 can only be installed in Zone 1. (If the LM-1 needs to be added to a different Zone in an existing system, this restriction may be simply overcome by swapping outputs and renaming the Zones.)

Set the two REMOTE MUSIC CONTROL buttons (LEV and SRC) for ZONE 1 on the rear panel to REMOTE (in). The buttons are immediately below the 4 x 3-pin REMOTE CONTROL PANEL CONNECTORS. This will disable the host unit's front panel music source and level controls for Zone 1.

Sometimes it is desirable to permit remote control of music level but keep music source selectable only on the host unit. In this case, set the SRC button for ZONE 1 back to FRONT PANEL (out). This will render the LM-1's music source switch inoperative, and return source selection to the front panel. See the 46-120/46-120MEDIA's Installation and User Guide for full details and jumper locations.