

# LE-I SERIES LINE INPUT MODULES

## LE-I: UK Version

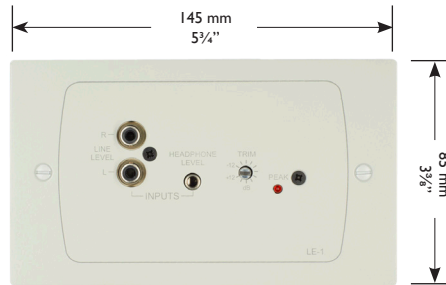

LE-1B



LE-1W

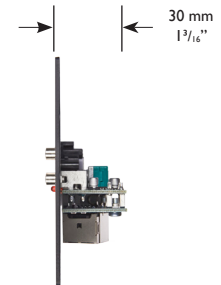

LE-1 side view

## LE-I: US Version



LE-1AB

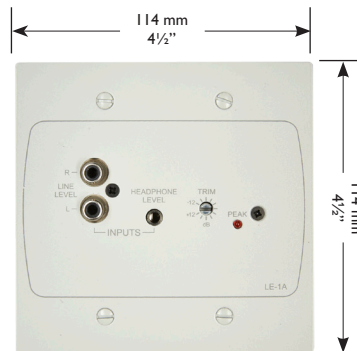

LE-1AW

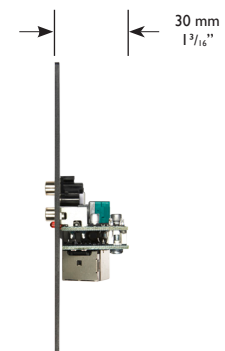

LE-1A side view

## LE-I: Euro-module Version



LE-1MB



LE-1MW

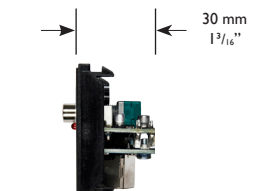

LE-1M side view

## General Description

The LE-I Series is a range of stereo, line level, remote input modules for use with the Cloud DCM1 range of Digitally Controlled Zone Mixers (see separate datasheets). All references to “DCM1” in this datasheet can be taken to apply to all versions in the DCM1 range.

In most DCM1 installations, the DCM1 host unit itself will normally be located in a rack along with other audio equipment, and will not be readily accessible. Installing an LE-I module in one of the DCM1’s zones provides the user with the ability to connect audio sources such as portable Hi-Fi systems, CD players, laptops, MP3 players, DJ mixers, radio mic receivers, etc., into the system. The DCM1 can then be configured in the usual way to route the source to loudspeakers in the same (or any other) zone.

Two types of input connector are provided: dual phono sockets for line level signals (with a nominal level of 0 dBu), and a 3.5 mm stereo jack socket for higher level signals (approx. +8 dBu nominal). Gain trim adjustment ( $\pm 12$  dB) is available on the faceplate, and a red “Peak” LED illuminates when an input signal exceeds nominal level.

Note that the LE-I is intended for the connection of unbalanced audio sources; the Cloud BE-I Series of remote input modules is also available when in-zone connection of balanced audio sources is required. Please see separate datasheet.

## Versions

Six versions of the LE-I are available; they are electrically identical and differ only in style and appearance. Versions available are:

- LE-IW to fit UK back boxes, white finish
- LE-IB to fit UK back boxes, black finish
- LE-IAW to fit US back boxes, white finish
- LE-IAB to fit US back boxes, black finish
- LE-IMW 100 x 50 mm Euro-module, white finish
- LE-IMB 100 x 50 mm Euro-module, black finish

The LE-IW and LE-IB mount into a standard dual-gang UK-style electrical back box; the LE-IAW and LE-IAB mount into a standard dual-gang US-style box. The LE-IMW and LE-IMB are “Media” versions: 100 mm x 50 mm Euro-modules, which can be fitted into either UK or other European back boxes with the appropriate mounting frame.

## Connections

The LE-I is exceptionally simple to install, as it connects to one of the DCM1’s Extension Ports with a single screened Cat 5 cable using standard shielded RJ45 connectors at each end. The Cat 5 cable carries DC power as well as balanced stereo audio.

The DCM1 has four dedicated Extension Ports for connection of remote input modules. (These are alternative connections to the DCM1’s Line Inputs 1 to 4; all the Line Inputs are also available on pairs of phono (RCA) sockets.) Any or all of the Extension Ports may be used for LE-I’s; note that when in use, the Line Input must be dedicated to the LE-I, and the corresponding phono sockets on the DCM1 rear panel should not be used for connecting additional equipment (see fig. 1).

A second “Link” connector is provided on the LE-I to permit multiple modules to be “daisy-chained” together, to provide insert points at different locations to the same Line Input. Signals applied to modules wired in this way will be summed together to the DCM1

Line Input to which the “last” LE-I in the chain is connected. An internal gating circuit on each module automatically disables the audio circuitry on any chained modules which are not in use, to minimise noise contribution. Chained modules will be treated as a single line input at the DCM1 (see fig. 2).

Note that LE-I input modules (unbalanced sources) may be freely intermixed with BE-I input modules (balanced sources) in such a chaining arrangement.

LE-I’s are powered from the DCM1 to which they are connected, and each takes 22 mA at +12 V and -12 V. In the vast majority of installations, the DCM1 will have ample spare power capacity for several LE-I’s. Note that the DCM1 is capable of powering other active accessories, such as other types of remote input module, or paging microphones. If these accessories form part of the system, the “spare” current available from the DCM1’s ports will be reduced. Full details are provided in the DCM1’s documentation.

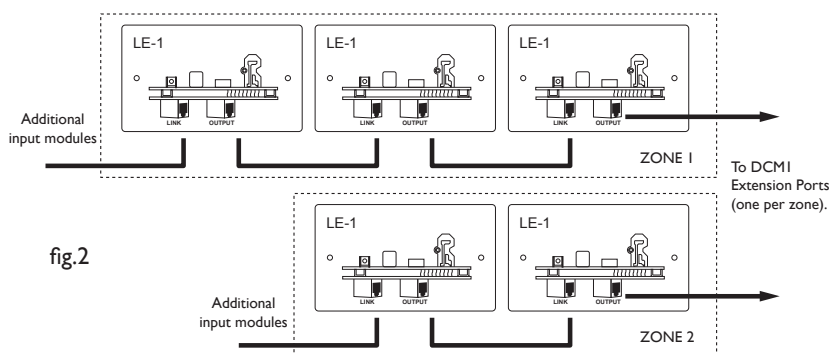
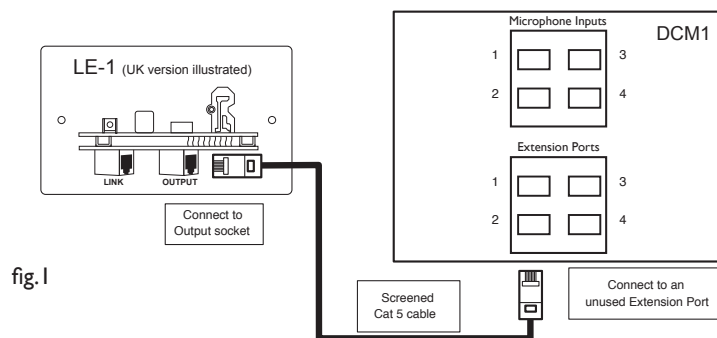

## System Example

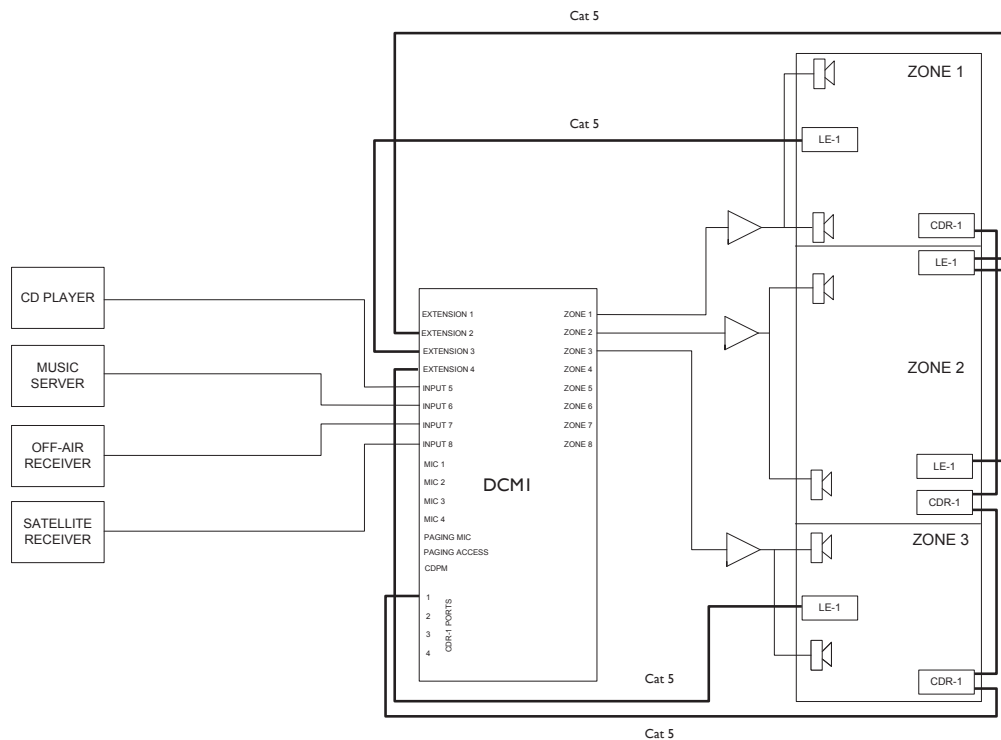

In the system shown, a DCMI is used to route a variety of audio sources to three zones. Each zone has a CDR-1 remote control plate installed, to allow the users in each area to select the audio source and control the volume locally.

Zones 1 and 3 each have one LE-1 remote input module installed, while Zone 2 has two. Zone 1's LE-1 is connected to Extension Port 3 on the DCMI; Zone 2's LE-1s are daisy-chained together and connected to Extension Port 2, and Zone 3's LE-1 is connected to Extension Port 4. Note that the Extension Ports used need have no numerical relationship to the zone outputs.

Any portable audio source connected to the LE-1 in Zone 1 will now be available to any zone in the system as Line Input 3; though in all likelihood it would normally be routed only to Zone 1, where it is fitted. The routing is made in the normal way using the DCMI's front panel display and controls, or may be selected from the CDR-1s installed throughout the system, if they have been enabled to do so. In the same

manner, audio sources connected to either of the LE-1s in Zone 2 are selectable throughout the system as Line Input 2, and the LE-1 in Zone 3 as Line Input 4. The DCMI permits Line Inputs to be renamed, so these sources could appear in the displays as e.g., "ROOM 1 INPUT".

The example also shows four "fixed" music sources connected to Line Inputs 5 to 8; these sources would probably be installed in the same location as the DCMI itself. These sources would also be available to any or all of the zones (unless barred from selection in particular zone(s) by the DCMI's Input Enable function).

## Architect's and Engineer's Specification

An optional remote input module shall be available for the Cloud DCMI range of Digitally Controlled Zone Mixers, and the module shall be compatible with all versions in the range. The module shall be provided with IN and OUT RJ45 connectors to permit connection to the DCMI host unit and other similar input modules via screened Category 5 data cable.

The remote input module shall allow the connection of a stereo unbalanced audio source; both phono (RCA) connectors and a 3.5 mm dia. 3-pole jack shall be accessible from the front of the module. The phono inputs shall be capable of accepting signals with a nominal level of 0 dBu, and the jack input signals with a nominal level of +8 dBu. A control of the preset type shall be provided to permit adjustment of the input gain of  $\pm 12$  dB. An LED shall illuminate when the nominal signal level is reached or exceeded.

The remote input module shall be available in versions suitable for fitment in standard UK or US dual-gang back boxes. There shall also be a version with a front panel measuring 100 mm x 50 mm suitable for mounting in standard Euro-style modular mounting frames. The modules shall be available in a choice of finishes.

The remote input modules shall be the Cloud LE-IW (UK version, white finish), the Cloud LE-IB (UK version, black finish), the Cloud LE-IAW (US version, white finish), the Cloud LE-IAB (US version, black finish), the Cloud LE-IMW (Euro-module, white finish) and the Cloud LE-IMB (Euro-module, black finish).

**Cloud Electronics Limited**

140 Staniforth Road, Sheffield, S9 3HF, England.  
Telephone: +44 (0)114 244 7051 Fax: +44 (0)114 242 5462  
Web: [www.cloud.co.uk](http://www.cloud.co.uk) E-mail: [info@cloud.co.uk](mailto:info@cloud.co.uk)

**Cloud Electronics USA**

2065 Sidewinder Drive, Suite 200, Park City,  
Utah 84060, United States of America.  
Toll Free: 0855 810 0161  
Web: [www.cloudusa.pro](http://www.cloudusa.pro) E-mail: [sales@cloudusa.pro](mailto:sales@cloudusa.pro)