

CV Series Digital Amplifiers

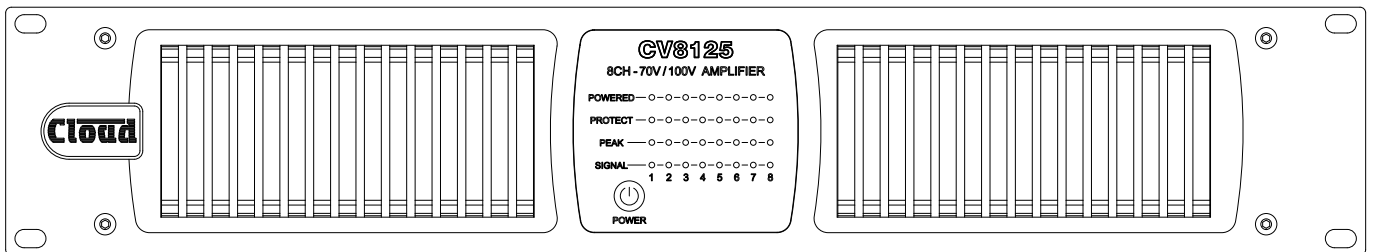



Quick Start Guide

WARNING:

To reduce the risk of fire or electric shock, do not expose this appliance to rain or moisture.

CAUTION:

	<p>WARNING: SHOCK HAZARD – DO NOT OPEN AVIS: RISQUE DE CHOC ÉLECTRIQUE – NE PAS OUVRIR</p>
	<p>The lightning flash with the arrowhead symbol within an equilateral triangle, is intended to alert you to the presence of uninsulated dangerous voltages within the product’s enclosure that may be of sufficient magnitude to constitute a risk of electric shock.</p>
	<p>The exclamation point within an equilateral triangle is intended to alert the user to the presence of important operating and maintenance (servicing) instructions in the literature accompanying the appliance.</p>

IMPORTANT SAFETY INSTRUCTIONS

1. Read these Instructions.
2. Keep these Instructions.
3. Heed all Warnings.
4. Follow all Instructions.
5. Do not use this apparatus near water.
6. Clean only with a dry cloth.
7. Do not block any ventilation openings. Install in accordance with the manufacturers’ instructions.
8. Do not install near any heat sources such as radiators, heat registers, stoves or other apparatus (including amplifiers) that produce heat.
9. Do not defeat the safety purpose of the polarized or grounding - type plug. A polarized plug has two blades with one wider than the other. A grounding type plug has two blades and a third grounding prong. The wide blade or the third prong are provided for your safety. When the provided plug does not fit into your outlet, consult an electrician for replacement of the obsolete outlet.
10. Protect the power cord from being walked on or pinched particularly at plugs, convenience receptacles, and the point where they exit from the apparatus.
11. Only use attachments/accessories specified by the manufacturer.
12.  Use only with the cart, stand, tripod, bracket or table specified by the manufacturer or sold with the apparatus, when a cart is used, use caution when moving the cart/apparatus combination to avoid injury from tip-over.

13. Unplug this apparatus during lightning storms or when unused for long periods of time.
14. Refer all servicing to qualified service personnel. Servicing is required when the apparatus has been damaged in any way, such as power-supply cord or plug is damaged, liquid has been spilled or objects have fallen into the apparatus, the apparatus has been exposed to rain or moisture, does not operate normally, or has been dropped.



Do not expose the apparatus to dripping or splashing, and ensure that no objects filled with water, such as vases, are placed on the apparatus.

L'appareil ne doit être exposé aux écoulements ou aux éclaboussures et aucun objet ne contenant de liquide, tel qu'un vase, ne doit être placé sur l'appareil.



The mains plug is used as the disconnect device and it should remain readily accessible during intended use. In order to isolate the apparatus from the mains, the mains plug should be completely removed from the mains outlet socket.

Le prise du secteur ne doit pas être obstruée ou doit être facilement accessible pendant son utilisation. Pour être complètement déconnecté de l'alimentation d'entrée, la prise doit être débranchée du secteur.

SAFETY INFORMATION

Safety notes regarding installation

- Do not expose the unit to water or moisture.
- Do not expose the unit to naked flames.
- Do not block or restrict any air vent.
- Do not operate the unit in ambient temperatures above 35 °C.
- Do not touch any part or terminal carrying the hazardous live symbol ⚡ while power is supplied to the unit.
- Do not perform any internal adjustments unless you are qualified to do so and fully understand the hazards associated with mains operated equipment.
- The unit has no user serviceable parts. Refer any servicing to qualified service personnel.
- If the moulded plug is cut off the AC power lead for any reason, the discarded plug is a potential hazard and should be disposed of in a responsible manner.

Conformities

This product conforms to the following European EMC Standards:

BS EN 55032:2012

BS EN 55024:2010

This product has been tested for use in commercial and light industrial environments. If the equipment is used in controlled EMC environments, the urban outdoors, heavy industrial environments or close to railways, transmitters, overhead power lines etc. the performance of the unit may be degraded.

This product conforms to the following electrical safety standard:

BS EN 62368-1:2014

This product is designed to be compliant with the relevant provisions of **Energy Star® Eligibility Criteria Ver 3.0 for Audio-Video products**.

RoHS and WEEE declaration

Cloud Electronics Limited manages its business and collaborates with its suppliers to comply with the European Union restriction of the use of certain hazardous substances in electrical and electronic equipment, RoHS Directive (2002/95/EC), that came into force on 1st July 2006, and similar restrictions in other jurisdictions.



The “crossed out wheellie bin” symbol on the product and represented above is there to remind users of the obligation of selective collection of waste. This label is applied to various products to indicate that the product is not to be thrown away as unsorted municipal waste. At the end of life, dispose of this product by returning it to the point of sale or to your local municipal collection point for recycling of electric and electronic devices.

Customer participation is important to minimize the potential effects on the environment and human health that can result from hazardous substances that may be contained in this product.

Please dispose of this product and its packaging in accordance with local and national disposal regulations, including those governing the recovery and recycling of waste electrical and electronic equipment. Contact your local waste administration, waste collection company or dealer.

Safety Considerations and Information

All models in the Cloud CV Digital range must be earthed. Ensure that the mains power supply provides an effective earth connection using a three-wire termination.

Caution – High Voltage

Do not touch any part or terminal carrying the hazardous live symbol while power is applied to the unit. Terminals to which the hazardous live symbol refers require installation by a qualified person.

Caution – Mains Fuse

The CV Digital amplifier contains no internal fuses. Mains over-current protection is provided by the fuse on the rear panel below the IEC connector; only replace this fuse with one of an identical type and rating.

Caution – Servicing

The unit contains no user-serviceable parts. Refer servicing to qualified personnel. Do not perform servicing unless you are qualified to do so. Disconnect the power cable from the unit before removing the top panel and do not make any internal adjustments with the unit switched on. Only reassemble the unit using bolts/screws identical to the original parts.

Introduction

This Quick Start Guide is intended to help you get a CV Digital amplifier installed and working as quickly as possible. The Guide will show you how to connect your sources and speakers to the amplifier, how to connect Cloud remote control plates and how to perform basic amplifier configuration. It also explains the amplifier's Power Sharing principle and covers the use of the Remote Power Down function, which allows the amplifier to comply with some regional emergency regulations.

IMPORTANT

The Quick Start Guide is not intended as a replacement for the full Installation and User Guide.

CV Series Digital Amplifiers have a wide range of advanced features and functions, many of which are accessible from the internal web server using a suitably-connected computer, tablet or smartphone. It is recognised that the additional flexibility afforded by these functions will not be needed for a great many installations, and in these cases, "out-of-the-box" operation can be achieved using the Quick Start Guide, without recourse to the web pages or knowledge of the amplifier's more sophisticated features.

Specifically, this Quick Start Guide does not cover configuration of the amplifier's internal DSP section (EQ, delay, limiting, crossovers, etc.), advanced routing options, external control via RS-232 or use of the GPIO ports. If your installation needs to use any of these functions, or if you are in any doubt about any of the points covered in the Quick Start Guide, please consult the full Installation and User Guide, which is available as a free download from www.cloud.co.uk/resources/.

It should be noted that some of the operating instructions in this Guide may become inapplicable if external web browser control is used, as external control is able to take priority over certain rear panel physical controls.

Unpacking the amplifier

The amplifier itself should be packed with the following items, in addition to this Quick Start Guide:

- IEC power cable
- A set of mating screw-terminal connectors for all rear panel connections.

CV Digital amplifier – models

There are four models in the range, which differ only in the number of channels available and the maximum power available from each channel. All models have a total output rating of 1 kW, and are designed to drive 70/100 V line loudspeaker systems directly. The models, with their nominal power ratings (see "Power Sharing" below), are:

- CV2500 – 2 channels, 500 W/ch
- CV4250 – 4 channels, 250 W/ch
- CV6160 – 6 channels, 160 W/ch
- CV8125 – 8 channels, 125 W/ch

The models are mechanically identical, and differ only in the number of LEDs on the front panel and the number of connectors on the rear panel, which reflects the number of channels.

Power sharing

A fundamental principle of the amplifier's design is the use of two separate internal power supplies, each rated at 500 W. The two supplies serve the odd- and even-numbered channels respectively. Each amplifier channel is actually capable of delivering 500 W, but this figure can only be realised if the other channels in its odd/even group are unused. As other channels in the same group are required to deliver power, the maximum power available from any one channel is reduced. The nominal ratings quoted above are the maximum power ratings per channel when all channels are simultaneously driven equally.

This principle allows installers to use some channels to drive speakers in areas where only low power is needed, and others for areas where more is needed.

It should be apparent that the 2 channel CV2500 is largely independent of the power sharing principle, having only one odd and one even channel.

Power requirements and turning the amplifier on and off

Connect the CV Digital amplifier to AC mains using the supplied IEC cable. The amplifier will operate on supply voltages from 85 to 265 V, 50 or 60 Hz.

The power button (⏻) is a “soft” type; press once to turn the amplifier on. All front panel LEDs will illuminate for a few seconds while internal diagnostics are conducted. The green LED adjacent to the power button will remain on after this sequence.

The amplifier is highly energy efficient and has an Automatic Power Down (APD) feature, which puts individual channels into Standby Mode after 30 minutes if no input signal to the channel has been detected. If no input signals are present when the amplifier is turned on, all channels will go immediately into Standby Mode. The power consumption in Standby Mode is approximately 2.5 W.

Press the power button again to turn the amplifier off.

If the mains supply is interrupted while the amplifier is on, the amplifier will execute the boot/diagnostic sequence automatically when power is restored.

Remote Power Down

The amplifier may be “forced” into Standby Mode applying a short-circuit to the rear panel **REMOTE PWR DOWN** connector. The connector is a 2-pin, 5 mm-pitch screw-terminal type. The amplifier will “wake up” when the short-circuit is removed: wake-up time is typically 200 ms. This function can be useful in shutting down e.g., visitor attractions at museums and theme parks.

Front panel LEDs

Each amplifier channel has four LEDs on the front panel, which function as follows:

- **POWERED** (green) – illuminates when the channel is active, i.e., it has been “woken up” when the input signal level exceeds -77 dBu (typical threshold: may vary with programme type).
- **SIGNAL** (green) – illuminates when the output signal level from the amplifier channel is at least 30 dB below the rated output level.
- **PEAK** (yellow) – with the channel’s limiter enabled (the factory default setting), the LED illuminates when the limiter is active, i.e., reducing gain. Note that the limiter settings are accessed via the browser control pages. When the limiter is disabled, the LED illuminates to indicate that the amplifier is clipping: this will normally indicate that the signal level is too high.
- **PROTECT** (red) – illuminates when the power amplifier stage is shut down by the internal protection circuitry. This will occur if excessive current or DC is detected at the output terminals, or if the internal temperature becomes too high. Over-current or DC fault conditions can be cleared by removing the AC power supply for a few seconds, but when the cause is over-temperature, the amplifier will remain in its protected state until the temperature drops (which will generally occur if the input signal is reduced).

Connections and adjustments

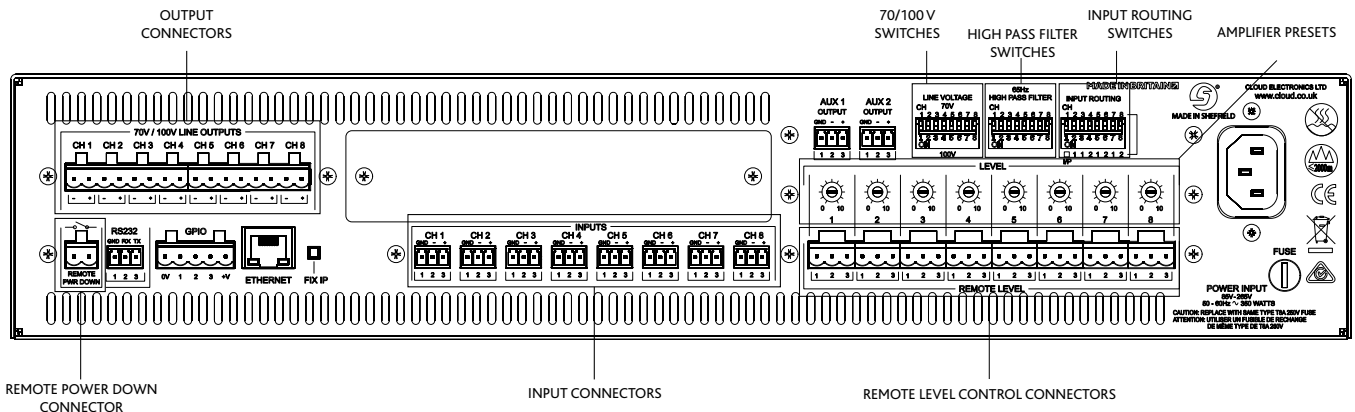

CV8125 8-Channel Digital Amplifier (shown as an example).

Other CV models with fewer channels provide the same functionality as the CV8125.

Inputs

The amplifier inputs are balanced. Each channel uses a separate 3-pin, 3.5 mm-pitch screw-terminal connector. Connect as shown below:

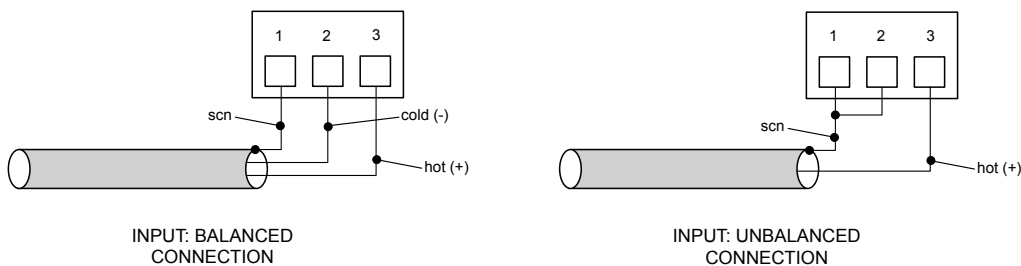

Outputs

The amplifier outputs can drive 100 V line or 70 V line loudspeaker systems directly. Check the **70V / 100V** DIP switches to ensure that they are in the correct position for the system voltage: there is one switch for each channel. (Note that on the CV6160, switches 7 and 8 are not used.)

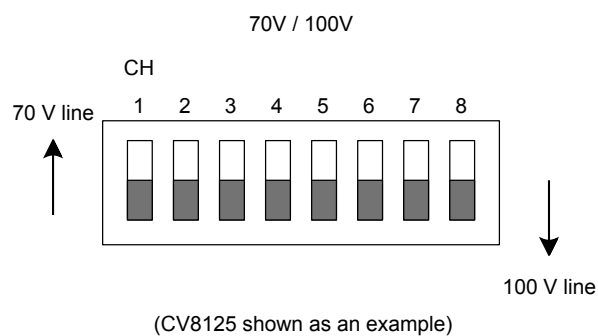

Each channel uses a separate 2-pin, 5 mm-pitch screw-terminal connector. Observe loudspeaker polarity: always connect all '+' terminals together, and all '-' terminals together.

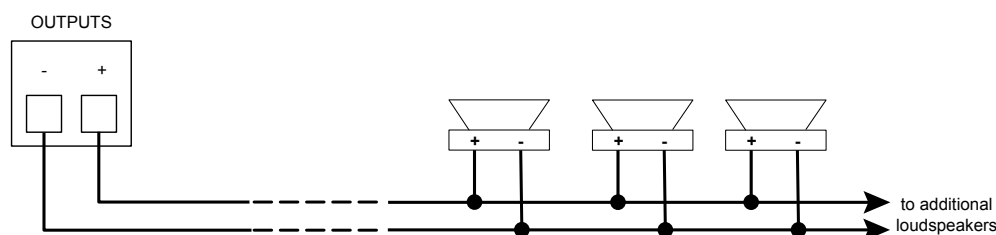

100/70 V line loudspeakers will generally include a tapped transformer with selectable power settings. When connecting large numbers of loudspeakers, always choose the correct tapping for the volume required in the physical area where the loudspeakers are fitted: e.g., speakers in quiet corridors will need a much lower power setting than those in noisy public areas. The total power rating of all the loudspeakers connected to a single amplifier channel should not exceed the maximum power that the channel is intended to provide (see section on "Power Sharing" on page 5) and should never exceed 500 W under any circumstances.

Each channel has a switchable 65 Hz hi-pass filter, selected by rear panel DIP switches. Programme material with high levels of low frequency may saturate the loudspeaker transformer cores, causing unpleasant distortion. We recommend that the filters are left in their factory setting of ON (switches down) if the relevant channels are being used for loud music. It may be possible to switch the filters OFF for other types of programme, but this should be assessed by listening tests. (Note that on the CV6160, switches 7 and 8 are not used.)

The maximum volume in each area can be adjusted with the preset **LEVEL** controls: each amplifier channel has its own control.

Input routing

In common with other Cloud power amplifiers, each amplifier channel can either be fed with a signal from its own input (the factory default setting), or with the signal feeding another channel. This allows the same input signal to feed several channels without the need for input connectors to be wired in parallel. CV Digital models with fewer channels are obviously restricted in the range of routing options available in comparison with models with more channels.

The rear panel **INPUT ROUTING** DIP switches are used to select input source for each channel, except Channel 1. The factory default setting is with all switches UP, which connects the input of each amplifier channel to the same-numbered input connector, as indicated on the upper row of numbers. Setting a switch DOWN parallels the input of that amplifier channel with the input of the amplifier channel indicated below the switch.

Notes:

- Switch 1 is inoperative on all models
- Switches 7 and 8 are inoperative on model CV6160

Example 1 (all models):

To feed Channels 1 and 2 with the same source, connect the source to Input 1 and set Switch 2 DOWN.

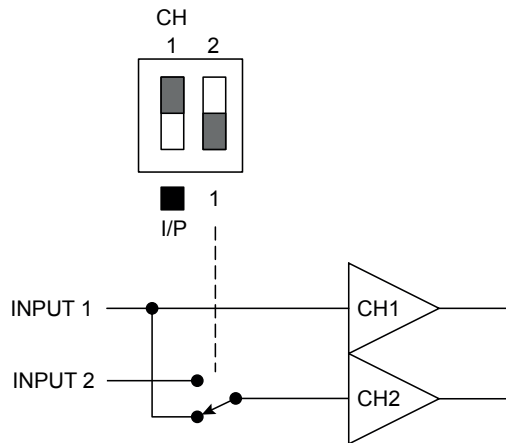

Example 1

Example 2 (models CV4250 up):

To feed Channel 1, 2, 3 and 4 with the same source, connect the source to Input 1 and set Switches 2, 3 and 4 DOWN.

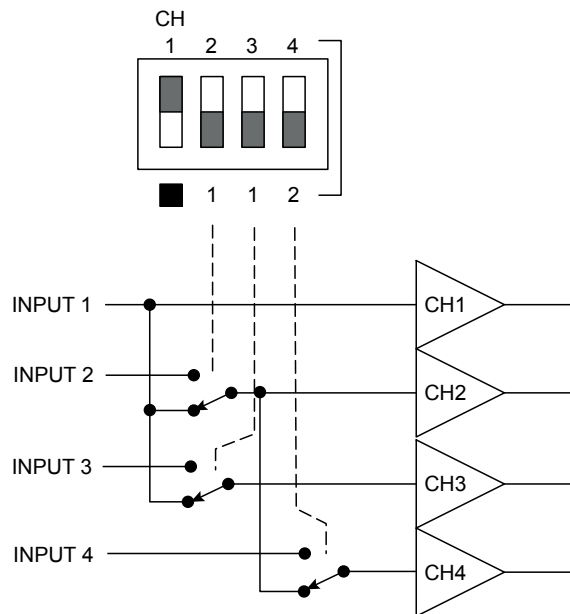

Example 2

Example 3 (models CV4250 and up):

To feed Channels 1 and 3 with the left signal from a stereo source, and Channels 2 and 4 with the right signal (thus forming a pair of stereo amplifiers), connect the left signal to Input 1, the right signal to Input 2, and set switches 3 and 4 DOWN, leaving switch 2 UP.

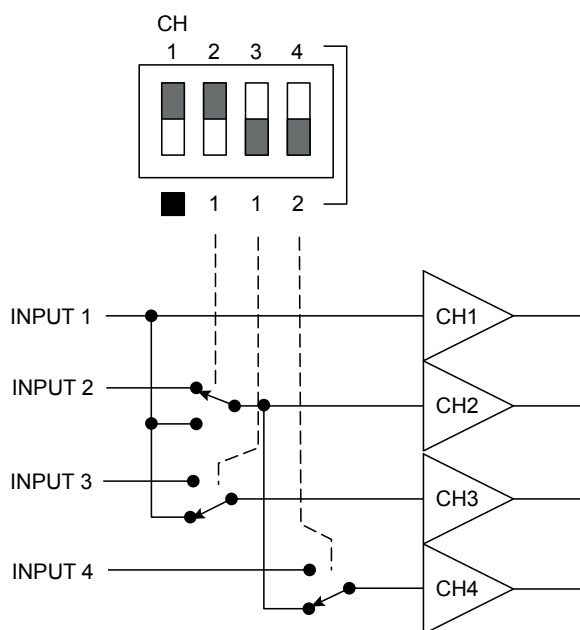

Example 3

Connecting Remote Control Plates

CV Digital amplifiers support remote volume control by Cloud RL-1 Series remote control plates.

Each channel has a 3-pin, 5 mm-pitch screw-terminal connector (**REMOTE LEVEL**) on the rear panel. Connect an RL-1 using two-core screened cable as shown:

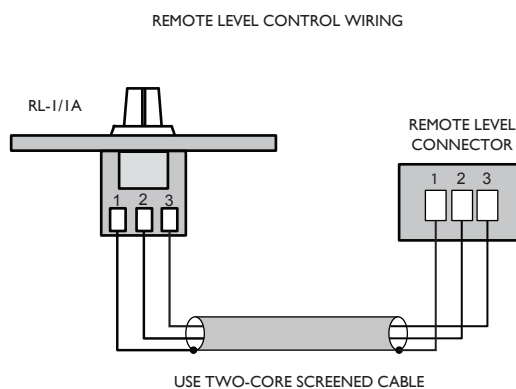

Maximum reliable cable run is 100 m. An RL-1 will control the level in the channel from zero ("off") to the maximum determined by the setting of the rear panel **LEVEL** preset control.

The **LEVEL** port responds to a control voltage in the range 0 to 10 V DC (where 0 V produces maximum level). A DC voltage in this range may be applied here to allow an external control system to vary the volume in each channel. Please see the Installation and User Guide for full details.

Using the Auxiliary Outputs

The two rear panel connectors **AUX 1** and **AUX 2** may be used to drive additional amplifiers, for recording, or any other purpose where system "expansion" is required. The connectors are 3-pin, 3.5 mm-pitch screw terminal type.

The signals at the auxiliary outputs are balanced and line level, and can thus be use to drive most external equipment directly. The connector pinout is identical to that used for the amplifier inputs:

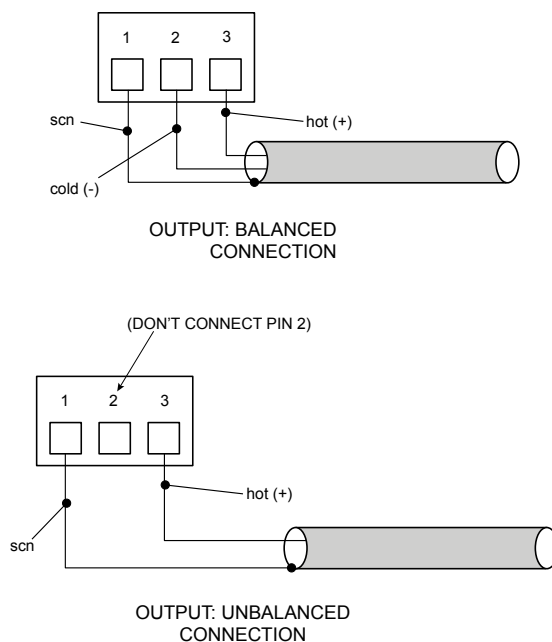

The factory default sources for outputs **AUX 1** and **AUX 2** are the signals routed to the inputs of Channels 1 and 2 respectively. It can be seen from the Input Routing examples from page 9 that in practice this means that **AUX 1** will always carry the signal applied to **INPUT 1**, and **AUX 2** will always carry the signal selected by **INPUT ROUTING** DIP switch 2 - either that applied to **INPUT 1** or that applied to **INPUT 2**.

Note also that the sources for the auxiliary outputs are effectively derived "post" the rear panel channel (the factory default setting) preset controls, and thus the **LEVEL** controls for Channels 1 and 2 will vary the output level at **AUX 1** and **AUX 2** respectively.

www.cloud.co.uk



www.cloudusa.pro